

# BLACK-PRIMERLESS PROCESS AUTO GLASS REPLACEMENT

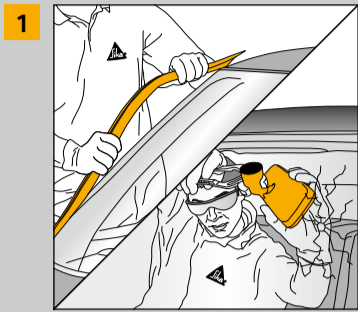

- Remove all decorative trims



- Cover the aperture with masking tape

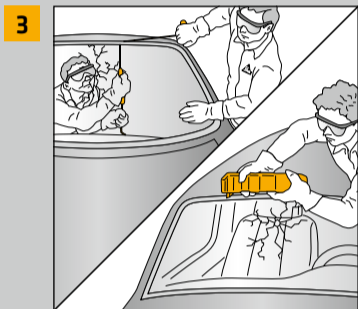

- Cut out damaged windshield using Sika SmartCut, electrical knife, cutting wire, cold knife etc.

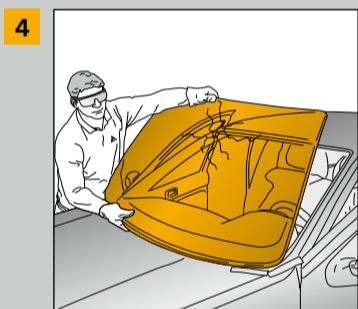

- Remove damaged windshield

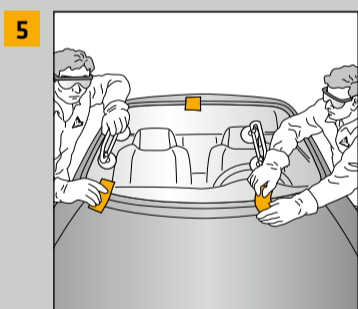

- Dry fit new windshield



- Clean the new windshield with Sika® Cleaner G+P

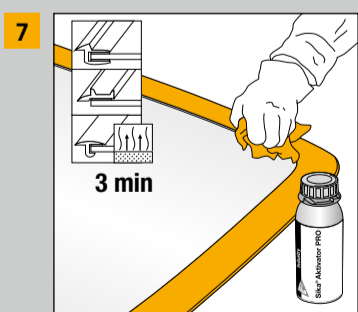

- Activate the bonding surface of the glass using Sika® Aktivator PRO

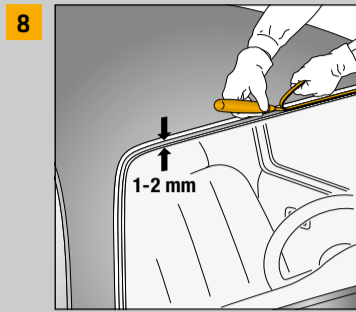

- Trim back the remaining adhesive bead to 1-2 mm

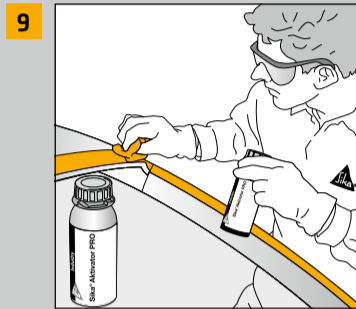

- Clean the aperture using Sika® Cleaner G+P and activate the remaining bead with Sika® Aktivator PRO



- Cover any minor damage to paint work using Sika® Primer-207. In case of larger areas contact your body shop or refer to the car manufacturer's specification

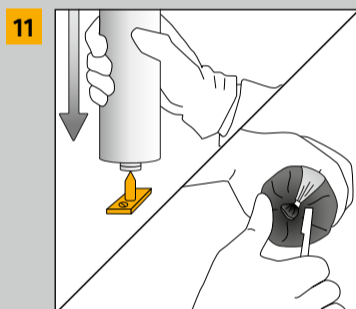

- Open the cartridge or the unipack

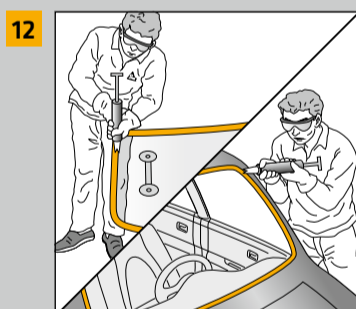

- Apply a triangular bead of adhesive either to the glass or the aperture

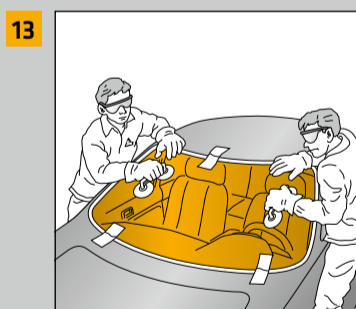

- Place the windshield in position within the open time of the adhesive

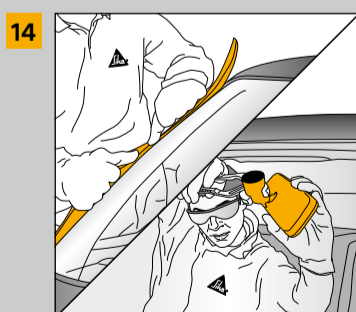

- Refit trims and mouldings



## BONDING SURFACE

Float Glass and Ceramic coated Glass<sup>a</sup>

Bare Metal Scratch < 5 cm<sup>2</sup>

Bare Metal 5 cm<sup>2</sup> to 150 cm<sup>2</sup>

Intact OEM Paint<sup>d</sup>

Repair Paint (after complete curing of paint)<sup>b, d</sup>

PVC/RIM Encapsulation<sup>b</sup>

Fresh Cut Bead<sup>d</sup>

Pre-applied adhesive system<sup>b</sup>

Polycarbonate<sup>c</sup>

PMMA<sup>c</sup>

● = Sika® Primer-207    ● = Sika® Aktivator PRO

## BLACK PRIMERLESS PROCESS

●

●

●●

●

●

●

●

●

●

Windshields without ceramic coatings need proper UV protection.

a) Glass pad must be clean of dirt and dust. Potential contamination must be removed, eg. by using Sika® Cleaner PCA

b) Scuff surface

c) Coating must be removed prior to use, scuff surface

d) Alternatively Sika® Aktivator-309 P can be used

Our most current General Sales Conditions shall apply.  
Please consult the most current local Product Data Sheet prior to any use.

[www.sika.com/aftermarket](http://www.sika.com/aftermarket)

**BUILDING TRUST**

